

"ASL" Acrylic Shelf Lip

Clear acrylic shelf lip with mounting holes.

Features

- 12"w x 2"h x 1/4"d
- 2 - ϕ .281 mounting holes
- Eased and flame polished edges

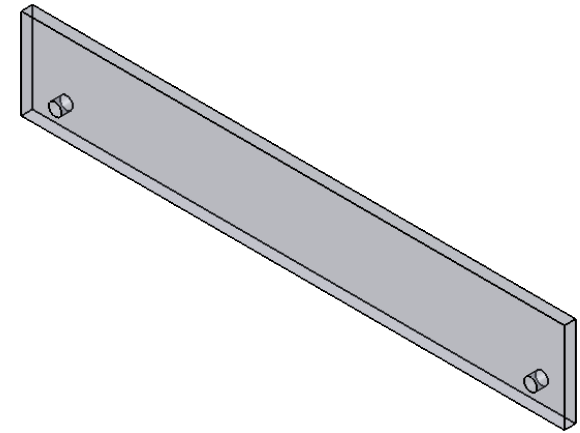

Product Dimensions

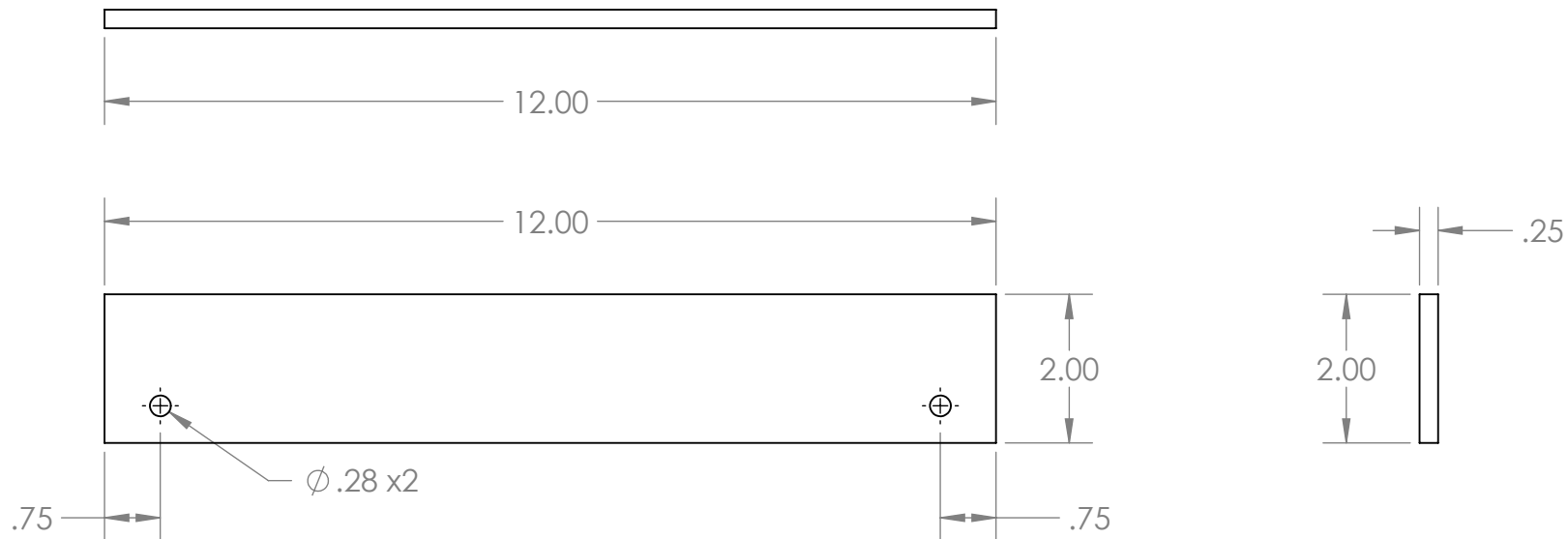

UNLESS OTHERWISE SPECIFIED:

DIMENSIONS ARE IN INCHES
TOLERANCES:
ANGULAR $\pm 2.50^\circ$
ONE-PLACE ± 0.5
TWO-PLACE ± 0.13

PROPRIETARY AND CONFIDENTIAL

THE INFORMATION CONTAINED IN THIS DRAWING IS THE SOLE PROPERTY OF INTER DYNE SYSTEMS. ANY REPRODUCTION IN PART OR AS A WHOLE WITHOUT THE WRITTEN PERMISSION OF INTER DYNE SYSTEMS IS PROHIBITED.

REV.	REVISION DESCRIPTION	DRAWN	CHECKED	DATE	COMMENTS:
A	STANDARD PRINT CREATED	ASR		10/05/20	



INTER DYNE SYSTEMS, INC
676 E. Ellis Rd., Norton Shores, MI 49441
Phone: 231-799-8760 Fax: 231-799-9690

PART NO.
ASL-12

QTY: N/A

MATERIAL: **.25IN ACRYLIC** FINISH: **CLEAR**