

NOTES:
 FRONT PANELS - 14GA
 REAR REMOVABLE PANELS - 14GA
 WALL STUDS - 16GA
 NO VISABLE FASTENERS FRONT FACING
 INSULATED

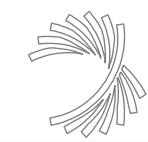

UNLESS OTHERWISE SPECIFIED:	REV.	REVISION DESCRIPTION	DRAWN	CHECKED	DATE	COMMENTS:
DIMENSIONS ARE IN INCHES TOLERANCES: ANGULAR ±1.0° ONE-PLACE ±0.060 TWO-PLACE ±0.030 THREE-PLACE ±0.015	A	SUBMITTALS SENT	JLC		11/26/24	
PROPRIETARY AND CONFIDENTIAL THE INFORMATION CONTAINED IN THIS DRAWING IS THE SOLE PROPERTY OF INTER DYNE SYSTEMS. ANY REPRODUCTION IN PART OR AS A WHOLE WITHOUT THE WRITTEN PERMISSION OF INTER DYNE SYSTEMS IS PROHIBITED.						
						QTY: 1



**INTER DYNE
 SYSTEMS, INC**
 676 E. Ellis Rd., Norton Shores, MI 49441
 Phone: 231-799-8760 Fax: 231-799-9690

PART NO.
213A GLASSWASH - MOD WALL
 MATERIAL: **14GA** FINISH: **304 #4**

NOTE:
DIMENSIONS ARE WALL TO WALL (EXCLUDING TRIM)
ALL DIMENSIONS MUST BE FIELD VERIFIED BEFORE FABRICATION

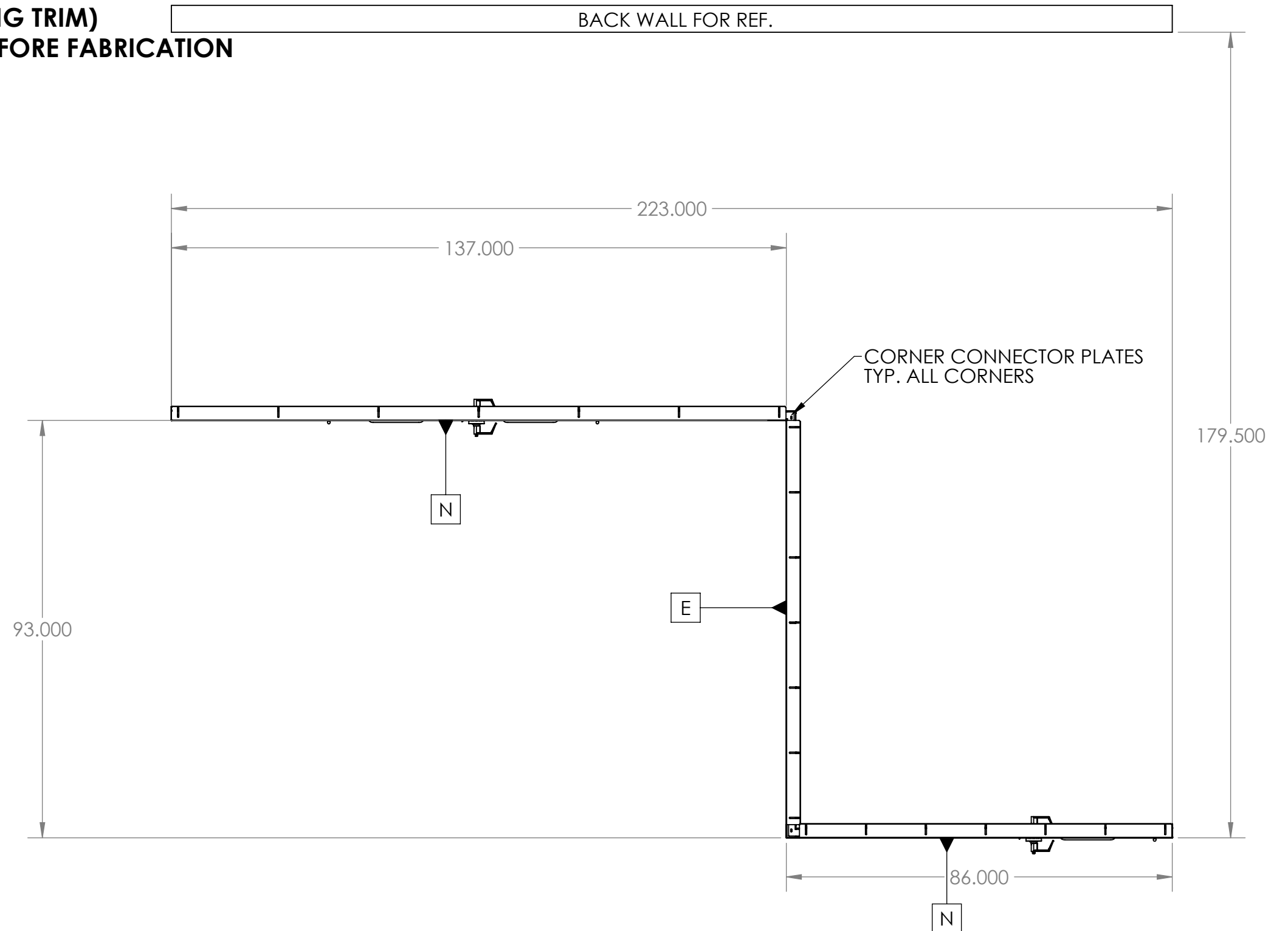

UNLESS OTHERWISE SPECIFIED:
 DIMENSIONS ARE IN INCHES
 TOLERANCES:
 ANGULAR ±2.50°
 ONE-PLACE ±0.5
 TWO-PLACE ±0.13

PROPRIETARY AND CONFIDENTIAL
 THE INFORMATION CONTAINED IN
 THIS DRAWING IS THE SOLE
 PROPERTY OF INTER DYNE SYSTEMS.
 ANY REPRODUCTION IN PART OR
 AS A WHOLE WITHOUT THE WRITTEN
 PERMISSION OF INTER DYNE
 SYSTEMS IS PROHIBITED.

REV.	REVISION DESCRIPTION	DRAWN	CHECKED	DATE	COMMENTS:
A	SUBMITTALS SENT	JLC		11/26/24	

QTY: 1

 **INTER DYNE SYSTEMS, INC**
 676 E. Ellis Rd., Norton Shores, MI 49441
 Phone: 231-799-8760 Fax: 231-799-9690

PART NO.
 213A GLASSWASH - MOD WALL

MATERIAL: 14GA FINISH: 304 #4

DETAILS

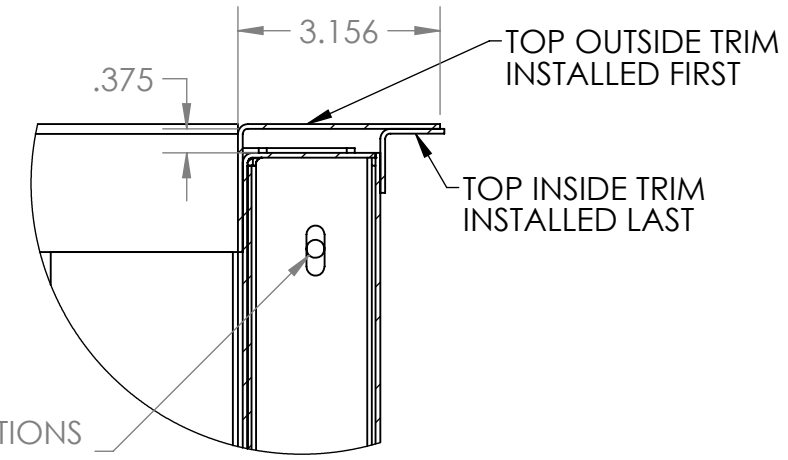

DETAIL C
SCALE 1 : 3

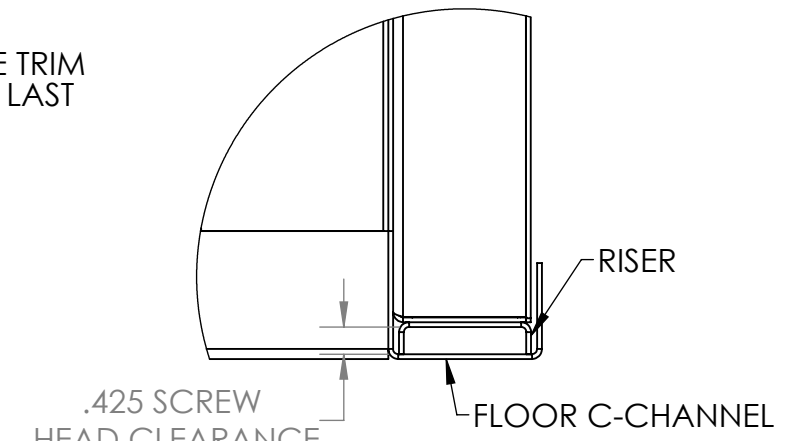

DETAIL B
SCALE 1 : 3

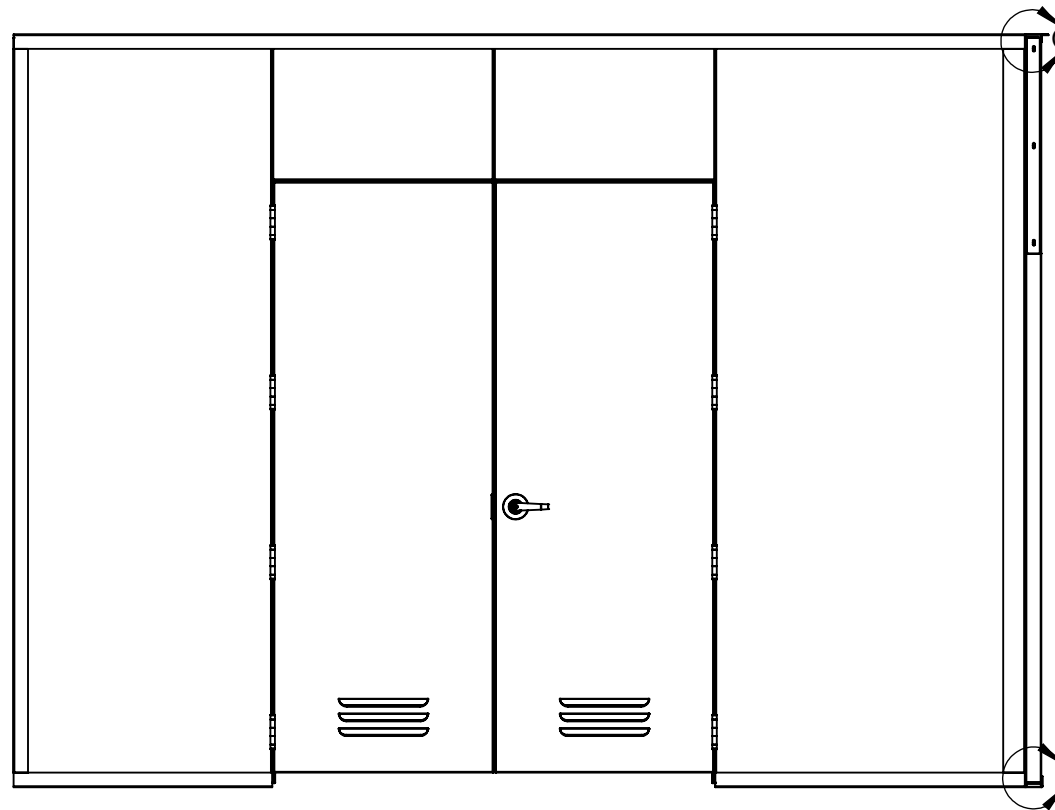
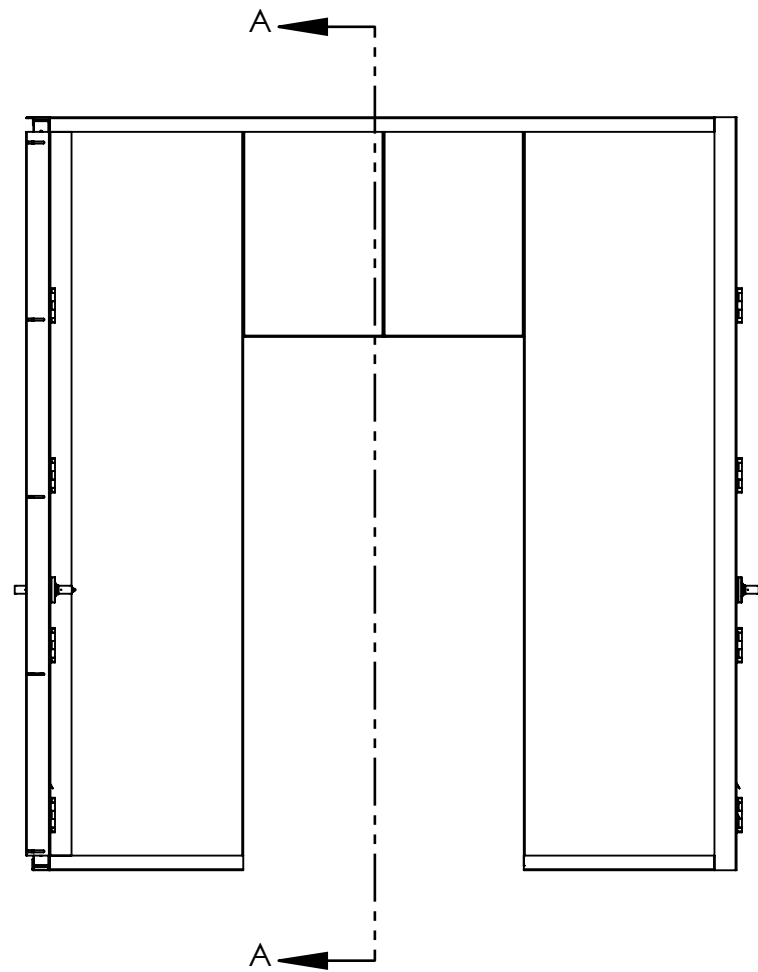

SECTION A-A
SCALE 1 : 26

UNLESS OTHERWISE SPECIFIED:
DIMENSIONS ARE IN INCHES
TOLERANCES:
ANGULAR ±2.50°
ONE-PLACE ±0.5
TWO-PLACE ±0.13

PROPRIETARY AND CONFIDENTIAL
THE INFORMATION CONTAINED IN THIS DRAWING IS THE SOLE PROPERTY OF INTER DYNE SYSTEMS. ANY REPRODUCTION IN PART OR AS A WHOLE WITHOUT THE WRITTEN PERMISSION OF INTER DYNE SYSTEMS IS PROHIBITED.

REV.	REVISION DESCRIPTION	DRAWN	CHECKED	DATE	COMMENTS:
A	SUBMITTALS SENT	JLC		11/26/24	

QTY: 1



INTER DYNE SYSTEMS, INC
676 E. Ellis Rd., Norton Shores, MI 49441
Phone: 231-799-8760 Fax: 231-799-9690

PART NO.
213A GLASSWASH - MOD WALL

MATERIAL: **14GA** FINISH: **304 #4**

TYPICAL DOOR DETAILS

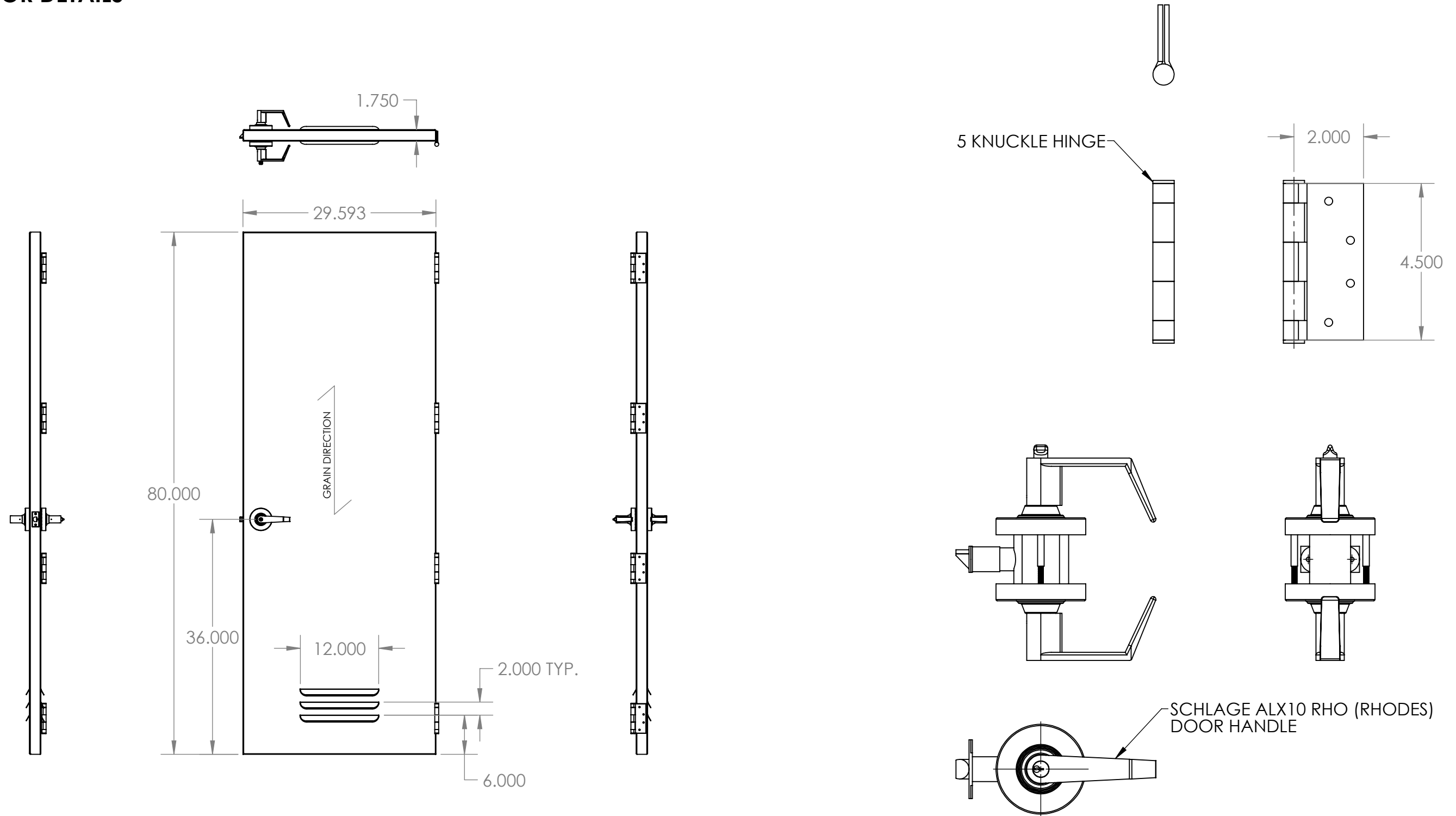

UNLESS OTHERWISE SPECIFIED:
 DIMENSIONS ARE IN INCHES
 TOLERANCES:
 ANGULAR ±2.50°
 ONE-PLACE ±0.5
 TWO-PLACE ±0.13

PROPRIETARY AND CONFIDENTIAL
 THE INFORMATION CONTAINED IN THIS DRAWING IS THE SOLE PROPERTY OF INTER DYNE SYSTEMS. ANY REPRODUCTION IN PART OR AS A WHOLE WITHOUT THE WRITTEN PERMISSION OF INTER DYNE SYSTEMS IS PROHIBITED.

REV.	REVISION DESCRIPTION	DRAWN	CHECKED	DATE	COMMENTS:
A	SUBMITTALS SENT	JLC		11/26/24	

QTY: 1



INTER DYNE SYSTEMS, INC
 676 E. Ellis Rd., Norton Shores, MI 49441
 Phone: 231-799-8760 Fax: 231-799-9690

PART NO.
 213A GLASSWASH - MOD WALL

MATERIAL: 14GA FINISH: 304 #4

TYPICAL TRIM DETAILS

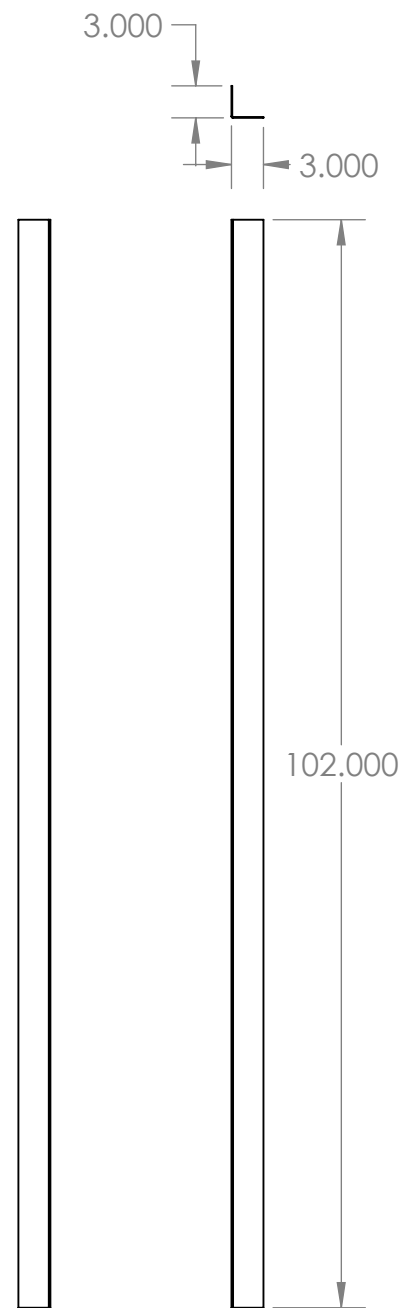

OUTSIDE CORNER TRIM

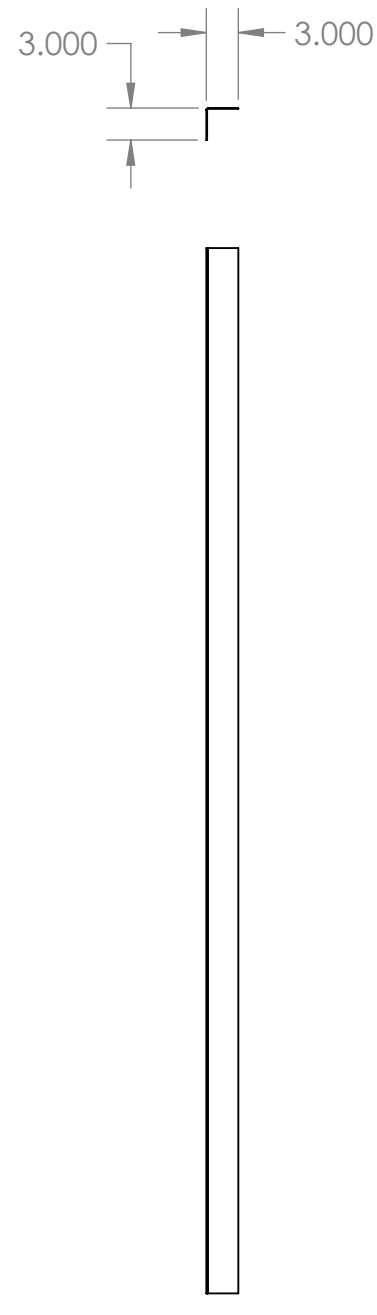

INSIDE CORNER TRIM

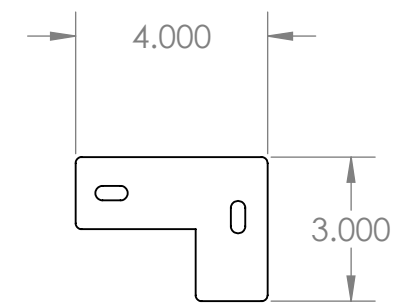

CORNER CONNECTOR

UNLESS OTHERWISE SPECIFIED:	REV.	REVISION DESCRIPTION	DRAWN	CHECKED	DATE	COMMENTS:
DIMENSIONS ARE IN INCHES TOLERANCES: ANGULAR ±2.50° ONE-PLACE ±0.5 TWO-PLACE ±0.13	A	SUBMITTALS SENT	JLC		11/26/24	
PROPRIETARY AND CONFIDENTIAL THE INFORMATION CONTAINED IN THIS DRAWING IS THE SOLE PROPERTY OF INTER DYNE SYSTEMS. ANY REPRODUCTION IN PART OR AS A WHOLE WITHOUT THE WRITTEN PERMISSION OF INTER DYNE SYSTEMS IS PROHIBITED.						
						QTY: 1

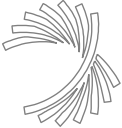

INTER DYNE SYSTEMS, INC
676 E. Ellis Rd., Norton Shores, MI 49441
Phone: 231-799-8760 Fax: 231-799-9690

PART NO.
213A GLASSWASH - MOD WALL

MATERIAL: 14GA

FINISH: 304 #4

